

## CLASSPAD EXERCISE – GAUSSIAN ELIMINATION

A natural foods store has three sizes of cans of mixed nuts. The *large* size contains 1 pound of cashews and 2 pounds of peanuts. The *giant* size contains 2 pounds of cashews, 4 pounds of peanuts and 1 pound of walnuts. The *mammoth* size contains 2 pounds of cashews, 6 pounds of peanuts and 1 pound of walnuts.

- a) Suppose that a customer places an order for exactly 15 pounds of cashews, 34 pounds of peanuts and 6 pounds of walnuts. How many cans of each type must be used to satisfy the customer's wishes with no nuts of any type left over? Set up a system of linear equations that describes this situation.
- b) Use your ClassPad to solve the system of equations from part a) in two ways.
  - i) Set up and apply Gaussian Elimination to (or use rref on) an appropriate augmented matrix. [HINT: The matrix should be three by four.]
  - ii) Find an appropriate inverse matrix and take the product of it and an appropriate three by one matrix. [HINT: The inverse matrix should be three by three.]
- c) Show that if the number of pounds of peanuts in the order had been twice the number of pounds of cashews in the order and it was possible to fill the order, we could fill the order using only large and giant cans. [HINT: Use your ClassPad to solve an appropriate system of linear equations with  $C$  for the number of pounds of cashews,  $2C$  for the number of pounds of peanuts and  $W$  for the number of pounds of walnuts.]
- d) Show that if the number of pounds of cashews in the order had been less than twice the number of pounds of walnuts in the order, it would not have been possible to fill the order. [HINT: Use your ClassPad to solve an appropriate system of linear equations with  $C$  for the number of pounds of cashews,  $P$  for the number of pounds of peanuts and  $W$  for the number of pounds of walnuts.]
- e) Show that if the number of pounds of cashews in the order had been more than one half of the number of pounds of peanuts in the order, it would not have been possible to fill the order. [HINT: Use your ClassPad to solve an appropriate system of linear equations with  $C$  for the number of pounds of cashews,  $P$  for the number of pounds of peanuts and  $W$  for the number of pounds of walnuts.]
- f) Let  $C$  be the number of pounds of cashews,  $P$  be the number of pounds of peanuts and  $W$  be the number of pounds of walnuts in an order. Find all values of  $C$ ,  $P$  and  $W$  for which the order can be filled using only giant size cans of mixed nuts. [HINT: You can do this part by letting  $C$  be the number of pounds of cashews,  $P$  be the number of pounds of peanuts and  $W$  be the number of pounds of walnuts in an order and discovering the relationship between  $C$ ,  $W$  and  $P$  in a solution with no large or mammoth cans. However, it is easier to use simple common sense to get an answer, and then perhaps confirm your conclusion using the algebraic approach.]

### SOLUTIONS:

- a)  $L + 2G + 2M = 15$ ,  $2L + 4G + 6M = 34$ ,  $G + M = 6$ , where  $L$ ,  $G$ ,  $M$  denote, respectively the number of large, giant and mammoth cans.

- b) The screen capture at the right shows that  $L = 3$ ,  $G = 4$  and  $M = 2$ .

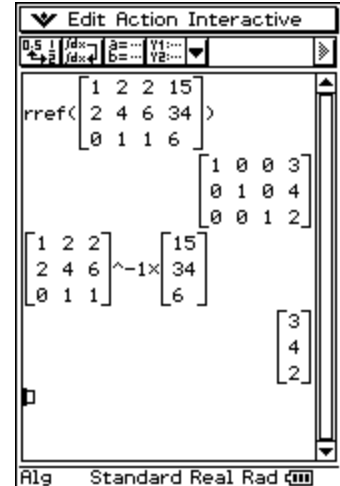

- c) The screen capture at the right shows that  $M$  must be 0.

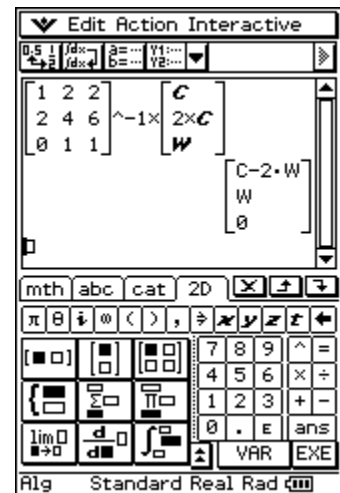

- d) The screen capture at the right shows that if  $C < 2W$ , then the value of  $L$  would be negative which is not possible.
- e) The screen capture at the right also shows that if  $C > P/2$ , then the value of  $M$  would be negative which is not possible.
- f) Since the giant size contains 2 pounds of cashews, 4 pounds of peanuts and 1 pound of walnuts, if only giant cans are used to fill an order the number of pounds of cashews must be twice the number of pounds of walnuts and the number of pounds of peanuts must be four times the number of pounds of walnuts. The screen capture at the right confirms this since if  $L = M = 0$ , then  $C = 2W$  and  $P = 2C = 4W$ . Note that for such an order, the number of giant cans needed equals the number of pounds of walnuts in the order.

